



hvBase-N

The hvBase-N-B14D10 is a combined negative high voltage generator and voltage divider for 10-stage photomultiplier tubes (PMT). It supports digital or analog high-voltage control and has a built-in digital temperature sensor.

Highlights

- Single supply voltage: 3.1 V to 5.5 V
- Power consumption:
70 mW at HV = 1000 V
- Standby mode: 0.5 mA at HV = 0 V
- PMT gain control via analog or digital input
- Digital temperature sensor
- Fits 2-inch to 5-inch PMTs
- Transistorized high voltage divider supports high PMT anode currents in excess of 50 μ A

Features

- The hvBase is intended for high-gain or high count rate spectroscopy applications where the average PMT current may reach 50 μ A.

- The power base incorporates a transistorized voltage divider chain, which presents a small load to the high voltage generator (50 M Ω to ground). At the same time it can support high average anode currents causing only minimal gain drifts in the photomultiplier.

- With a 3.3 V power supply and a high voltage of 1000 V the device consumes only 70 mW.

- The supply current is proportional to the PMT high voltage and reduces to only 0.5 mA when the high voltage is set to zero.

- The hvBase is mounted on a JEDEC B14 socket. Including the socket, the power base is about 2.2 inches tall.

- Related devices: Other members of the hvBase family support positive HV, different PMT pinouts and 8 to 10 dynodes.

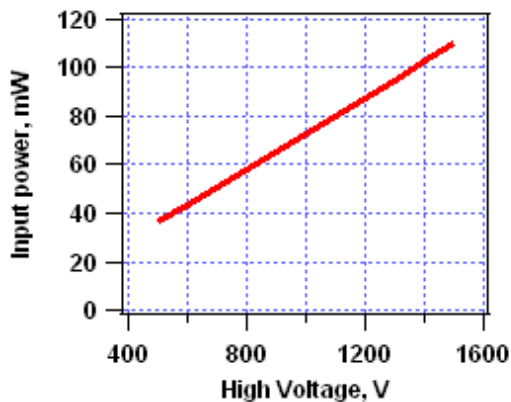

Figure 1: Power draw vs. high voltage.

At HV = 1.0k V the supply current is only 21 mA at V_{ss} = 3.3V. For a 24-hour period that is a charge of about 0.50 Ah.

Three AA NiMH rechargeables (1.8 Ah) will power this system for 3.6 days.

Specifications $V_{SS} = 3.3V$ unless otherwise noted

<i>Parameter</i>	<i>Symbol</i>	<i>Min</i>	<i>Typ.</i>	<i>Max</i>	<i>Comment</i>
General					
Supply voltage	VSS	3.1V	3.3V	5.5V	
Ripple voltage	VRR				HV=1000V
HV temperature drift	$\Delta HV / \Delta T$		+100ppm/K		
HV range	HV_out	550V		1500V	
Max. HV output current	I_{HV}		100 μ A		HV = 1000V
Quiescent current	I_q		1.3 mA	1.5 mA	HV = 0V
Supply current, no load	I_{SS}		21mA		HV = 1000V
Supply current, high load	I_{SS}		70mA		HV = 1000 V, $I_{anode} = 50\mu A$
HV					
DC-impedance at cathode	ZC	54 M Ω	56 M Ω	58 M Ω	VSS = 3.3V
DC-impedance at dynode 10	ZD10		20 k Ω		
HV-capacitance	CHV	15nF	16.7nF	18nF	
HV-drop vs pulse charge	$\Delta HV / \Delta Q$		60mV / nC		
Anode impedance to ground	ZA	99 k Ω	100 k Ω	101 k Ω	
Output ripple	Vrip		25mVpp @ 50kHz		HV=1000V
Control interface					
HV / V_{set}	M	0.980	1.000	1.020	at HV = 1000 V
V_{ctrl} input impedance		0.99 M Ω	1.00 M Ω	1.01 M Ω	
Environmental					
Operating Temp.	Top	0 $^{\circ}$ C		70 $^{\circ}$ C	cf Note 1

Note 1: Contact factory for extended operating temperature range of -40 $^{\circ}$ C to +85 $^{\circ}$ C.

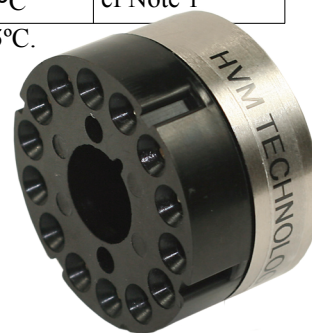

Performance

hvBase-N

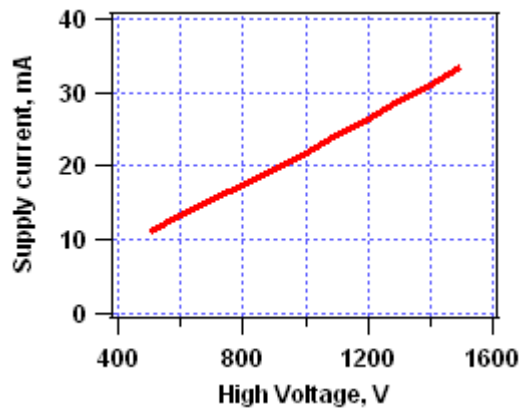

Figure 2: The supply current current is proportional to the high voltage: about 21mA/kV.

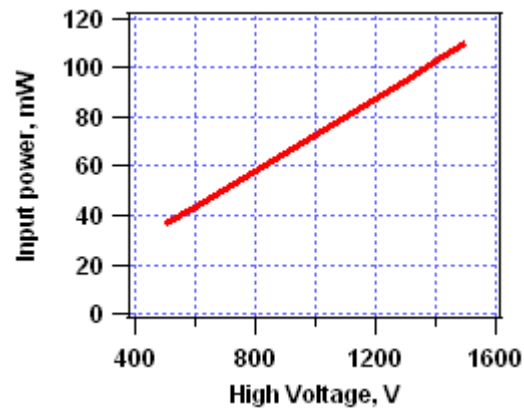

Figure 3: Supply current vs. output high voltage for PMT currents of 0, 50 μ A and maximum value.

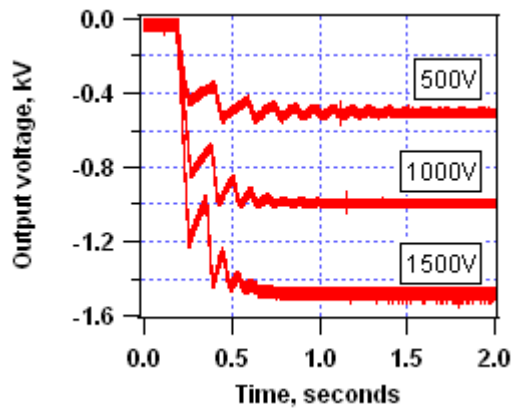

Figure 4: Turn-on behavior. Response to a step on Vctrl for a 0V to 500V, 1000V and 1500V step.

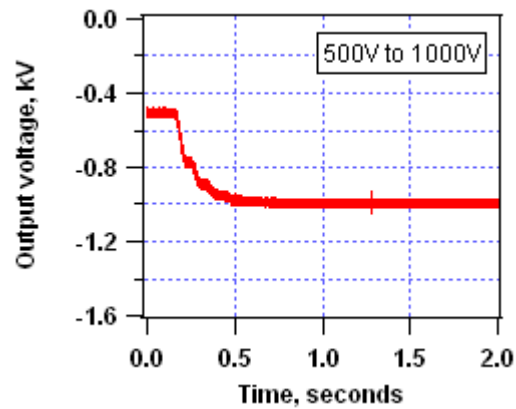

Figure 5: Turn-on behavior. Response to a step on Vctrl from -500V to -1000V output.

Divider ratio

For HV = -1000 V the cathode and dynode voltages are, in volt:

<i>K</i>	<i>F</i>	<i>D1</i>	<i>D2</i>	<i>D3</i>	<i>D4</i>	<i>D5</i>	<i>D6</i>	<i>D7</i>	<i>D8</i>	<i>D9</i>	<i>D10</i>	<i>A</i>
-1000	-869	-738	-679	-619	-560	-500	-440	-381	-321	-262	-131	0
2.2R	2.2R	R	R	R	R	R	R	R	R	R	2.2 R	2.2 R

Functional Block Diagram

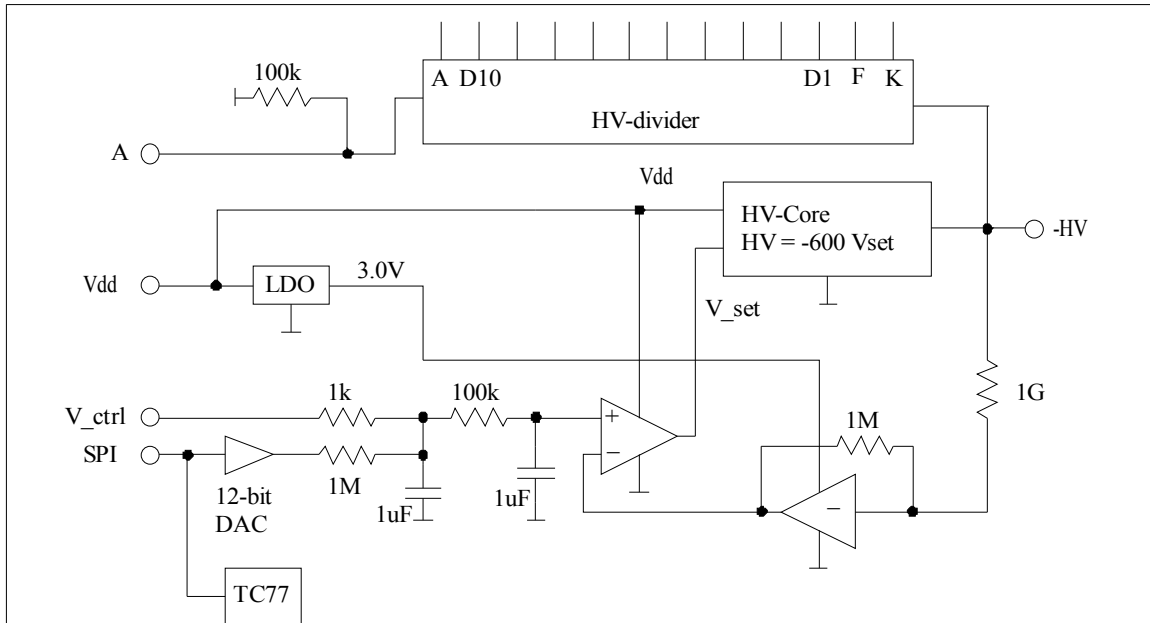

Drawing 1: Schematic of the power base. The error amplifier compares an attenuated version (1000:1) of the high voltage with the input voltage at its positive input. Hence the output voltage is -1000 times the control voltage (V_{ctrl}). Note that a positive control voltage is used to create a negative high voltage. The input voltage is provided through the V_{ctrl} input or by the DAC. Disconnect V_{ctrl} when using the DAC.

A single supply, V_{dd} , powers the entire circuitry including all amplifiers.

The high voltage divider is fed the negative high voltage. Voltage taps are provided to power the cathode (K), the focus electrode (F) and the 8 dynodes of the PMT. The anode is DC-coupled and there is a safety resistor of 100 k Ω to ground.

HV generator

The hvBase consists of transformer-based high voltage generator and a transistorized high voltage divider that feeds the photomultiplier dynodes and the cathode.

The high-voltage generator core is a proportional module that creates an output voltage 600 times higher than its input voltage. Linear control circuitry compares the actual high voltage with the required high voltage.

Users can set the high voltage through an 8-pin connector on the top of the hvBase. The pin out is shown in the table below.

<i>Pin</i>	<i>Name</i>	<i>Function</i>
1	GND	Ground
2	V_CTRL	Analog HV control
3	SPI_CLOCK	SPI-bus clock
4	T_CSB	Temperature select
5	D_CSB	DAC select
6	SPI_DATA	SPI-bus data
7	VD33	Supply voltage (3.3V)
8	Anode	PMT anode signal

Table 1: Pinout of connector J1.

In the most simple case, an analog voltage will be applied to V_ctrl. The V_ctrl input connects to a buffer amplifier with a very high input impedance via a 1 k Ω , 1 μ F RC-filter. The same amplifier input is connected to a DAC via a 1 M Ω resistor. The DAC powers up with a zero output voltage and remains at that setting if not externally programmed. Hence, a voltage applied at the V_ctrl input will override any DAC voltage, and the resulting nominal high voltage will be -1000 times the value of V_ctrl.

Ripple reduction and immunity to large scintillator / PMT pulses are dramatically

improved by the built-in 16.7 nF high-voltage filter capacitance.

HV-DAC

Alternatively to using the analog V_ctrl input to control the HV, there is an on-board 12-bit serial DAC (AD5310 from Analog Devices, or equivalent). It's interface is SPI™ and Microwire™ compatible. The DAC pins are accessible through connector J1. The DAC reference voltage is 3.0V \pm 1%. Hence, a digital value of 4095 corresponds to V_DAC = 3.000V. Since V_ctrl overrides V_DAC, be sure to disconnect V_ctrl when using the DAC.

The temperature sensor

The hvBases include a digital temperature sensor, TC77, from Microchip (www.microchip.com) with an interface that is SPI™ and Microwire™ compatible. It is accessible through connector J1. The sensor measures the power base temperature once per second with a resolution of 0.0625°K and an accuracy of 1K.

The SPI interface

The high voltage controlling DAC and the digital temperature sensor share the SPI bus. The data and clock line are shared, but the two select lines are not. They are active low and have internal pull up resistors (100k) so they can each be left unconnected if the respective device is not used.

T_CSB should be pulled high after a temperature read to tri-state the TC77 serial data output. T_CSB must be pulled high while attempting to reprogram the DAC. The DAC only reacts to clock and data on the SPI bus after a high-to-low transition on D_CSB. When not in use, D_CSB can be pulled low or high. Pull low to minimize standby current at HV=0.

Environmental

The units are fully potted and sealed against intrusion of moisture or dust. The 8-pin connector is IP67 certified and splash proof.

Outline drawing

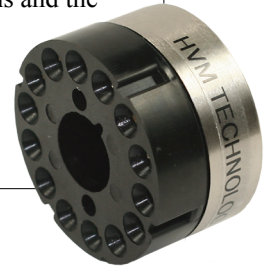
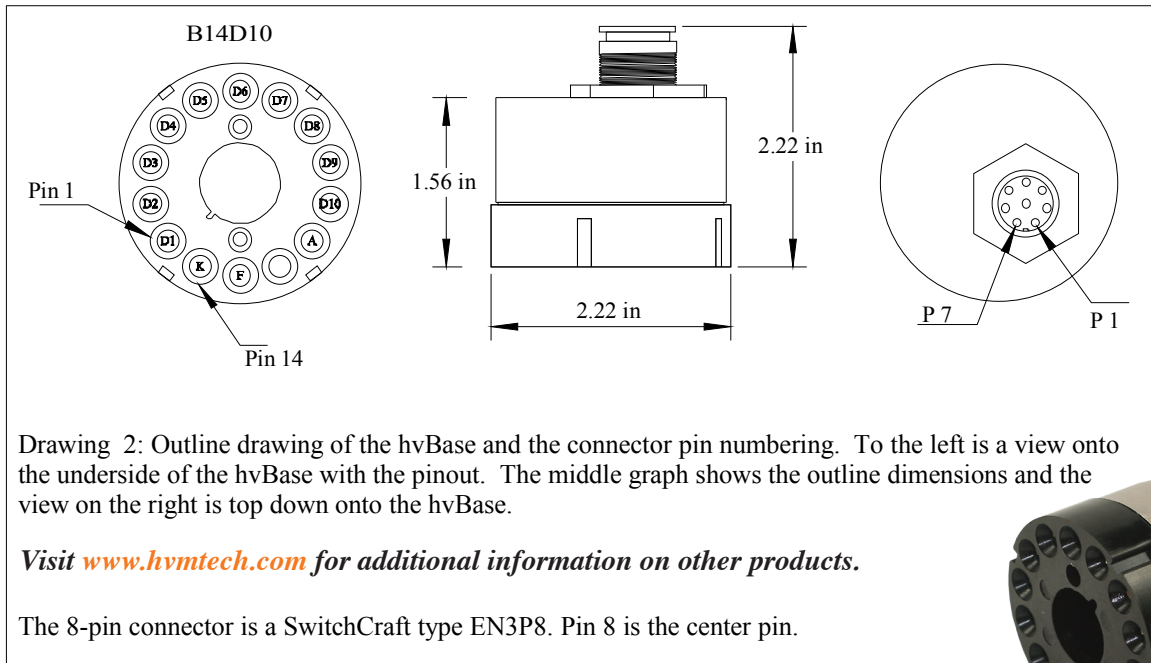

Absolute maximum ratings

Exceeding the absolute limits will most likely damage the device. Correct operation is not guaranteed at these limits. Operational limits are shown next to the absolute limits.

Parameter	Limits	
	Absolute	Operation
V _{supply}	-0.5 V to +5.5 V	3.1V – 5.0V
V _{set}	-0.5V to +3.3V	0V – 1.5V
HV out	1500V	500V – 1500V
Temperature	-40°C to +85°C	0°C to +70°C
Humidity	0 to 99%	0 to 95%, non condensing

Compatibility

hvBase-N

Compatibility chart

The chart below shows photomultipliers that have pinouts compatible with this hvBase. Consult the data sheets of other hvBases if a particular PMT is not in this list. Secondly, as manufacturer's continue to add new PMTs to their catalogs, this cannot be a complete list.

<i>Pin out</i>	<i>PMT Size</i>	<i>Manufacturer</i>	<i>Part numbers</i>
B14D10	2-inch	ADIT	B51D01W, B51B03W, B51D03W
		Electron Tubes	9215KB, 9250KB, 9250QB, 9256KB, 9266KB, 9428KB, 9956KB
		Hamamatsu	R550, R2154-02
		Photonis	XP2202B, XP2203B, XP3230B, XP3232B, XP6242B, XP83019B
3-inch	ADIT	ADIT	B76D01W
		Electron Tubes	9265KB, 9269KB, 9302KB, 9305KB, 9311KB, 9318KB
		Photonis	XP3330B, XP3332B, XP6342B, XP83021B
3.5-inch	ADIT	ADIT	B89D01W
		Electron Tubes	9306KB
		Photonis	XP3730B, XP3732B, XP83013B
5-inch	ADIT	ADIT	B133D01W
		Electron Tubes	9390KB
		Hamamatsu	R877, R1513
		Photonis	XP3540B, XP83006B

Pin 1														Pin 14
D1	D2	D3	D4	D5	D6	D7	D8	D9	D10	A	-	F/G	K	

B14D10 pinout

Revision history:

R1 May 2010 Original release